

DESCRIZIONE

Le valvole Serie **TM10** sono del tipo a tre vie a corpo unico con funzione miscelatrice (due ingressi, un uscita).

Progettate per garantire un controllo preciso ed efficace su tutto il campo di regolazione, in tutte le condizioni di esercizio, le valvole Serie TM10 sono dotate di attuatori pneumatici o elettrici per soddisfare tutte le esigenze di controllo e di regolazione quali: acqua, acqua surriscaldata, vapore saturo, olio diatermico, gas e tutti gli altri fluidi purchè compatibili con i materiali impiegati.

DESCRIPTION

The OMC **TM10** Series is a three-way globe-style control valve for applications requiring mixing flow in a process control system. The open flow paths and simple construction provide a reliable and easy-to-maintain valve solution. TM10 series could be manufactured with pneumatic or electric actuators to meet all specific requirements of fluid control (water, steam, thermal oil, gas and other liquids) whether compatible with the material used.

DN15 ÷ DN200



**CALCOLATE SECONDO LA NORMA EN12516-2
CON EXTRA SPESSORE C=6mm**

**ACCORDING TO EN12516-2 STANDARD
WITH EXTRA THICKNESS C=6mm**



Directive 97/23/EC
Direttiva 97/23/CE

PED



Disponibile - Available 94/9/EC (ATEX):
II 2 G IIC c X Gb / II 2 D IIIC c X Db

CARATTERISTICHE COSTRUTTIVE

Da DN15 a DN200
Otturatore guidato "Top Guide" standard per garantire maggior stabilità
Morsetto CEI EN 60534-6-1 std (ex.IEC534)
Packing a doppia tenuta
Classe di tenuta : IV (Std)

DESIGN FEATURES

From DN15 to DN200
Top Guided std construction ensure plug stability
CEI EN 60534-6-1 clamp Std (ex.IEC534)
V-Ring double packing
Shutoff capabilities : Class IV (Std)

OPZIONI

Sede e otturatori induriti da nitrurazione salina.
Passaggi ridotti su misura
Packing con soffiello di tenuta per emissioni "ZERO" (ZEB20)
Bonnet allungato per basse temperature
Bonnet alettato per alte temperature
Costruzione conforme NACE0175/2003 o ISO15156 (su richiesta)
Gamma completa di accessori (posizionatori, ritrasmissione, lock -up, contatti di allarme, etc...)

OPTIONS

Hardened trims by Saline Nitriding
Reduced area trim to provide wide capabilities for all sizes
Bellows seal to meet zero emissions (ZEB20)
Extended bonnet for low temperature
Finned bonnet for high temperature
NACE 0175/2003 or ISO15156 Construction on request
Available accessories : positioners, position transmitter, limit switches, lock-up etc..

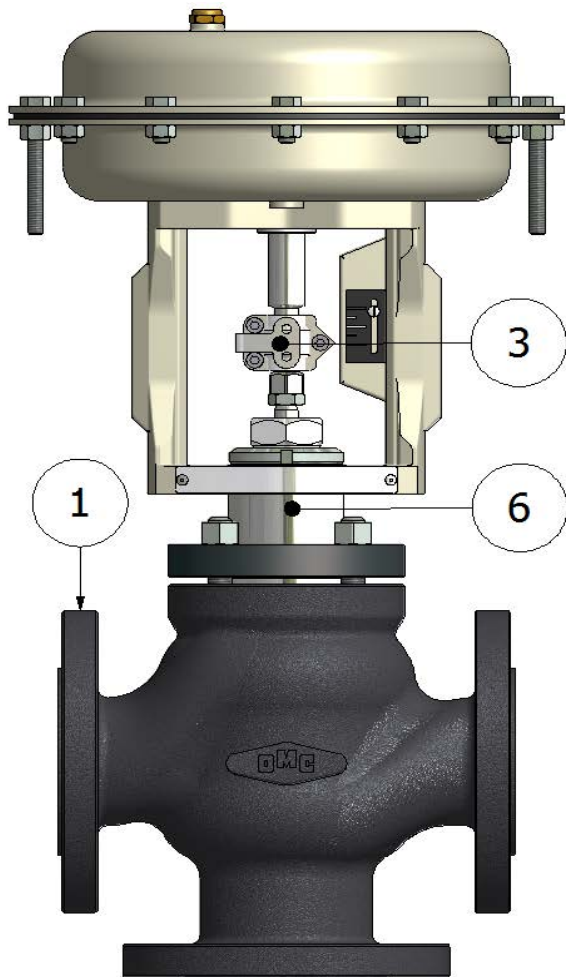

LEGENDA

1- Corpo valvola
2- Gruppo Premistoppa
3- Connessione accessori IEC534
4- Molle Attuatore
5- Castello
6- Bonnet
7- Profilo superiore Otturatore
8- Profilo inferiore Otturatore
9- Sede Inferiore
10- Sede Superiore
11- Membrana Attuatore
12- Box Attuatore

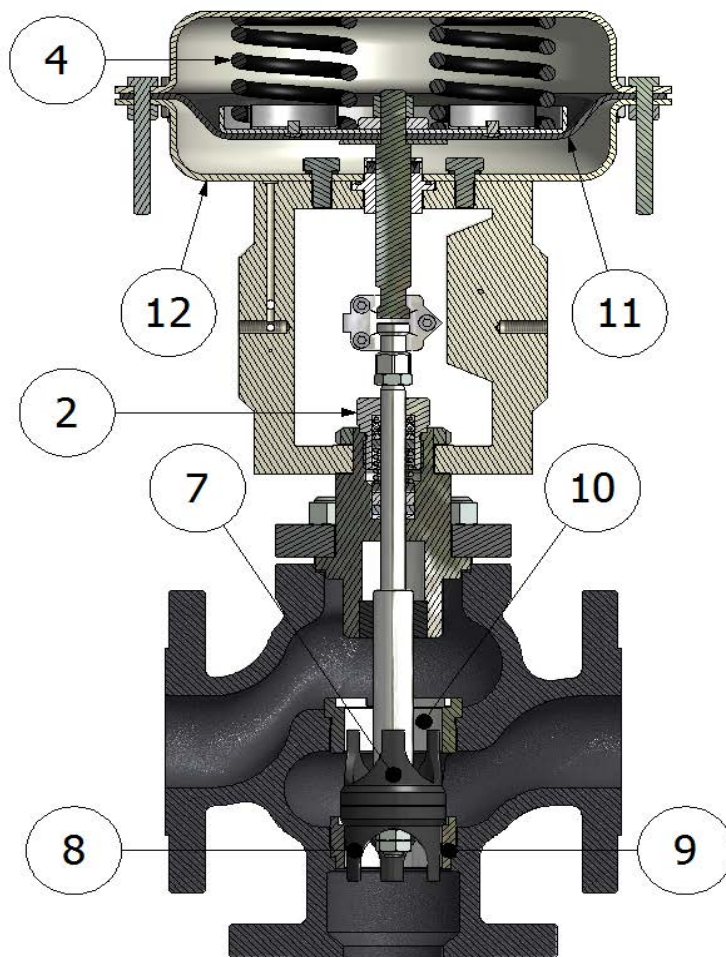

LEGENDA

1- Body Valve
2- Packing
3- Top Stem Connector (IEC 534)
4- Actuator Springs
5- Yoke
6- Valve Bonnet
7- Upper Plug
8- Lower Plug
9- Lower Seat
10- Upper Seat
11- Diaphragm
12- Actuator casing

DATI TECNICI CORPO VALVOLA

TIPO	Globo
DIAMETRI NOMINALI	da DN15 a DN200
RATING DEL CORPO	PN16 - PN40
SCARTAMENTO	EN 558-1
FLANGE	EN 1092

VALVE BODY CHARACTERISTICS

Style	Globe valve
SIZES	from DN15 to DN200
PRESSURE RATING	PN16 - PN40
BODY FACE TO FACE DIMENSIONS	In accordance with EN 558-1
FLANGES CONNECTIONS	EN 1092

MATERIALI GRUPPO CORPO STD

Corpo Valvola: Ghisa Sferoidale EN-GJS-400-18 (EN-JS1025)	Bonnet: ASTM A105
	Otturatori: ASTM 351 CF8M Sedi: ASTM A182 F316
Corpo Valvola : Acciaio al Carbonio A216 WCC	Bonnet: ASTM A105
	Otturatori: ASTM 351 CF8M Sedi: ASTM A182 F316
Corpo Valvola: Acciaio INOX A351 CF8M	Bonnet : ASTM A182 F316
	Otturatori: ASTM 351 CF8M Sedi: ASTM A182 F316

STD BODY & TRIM MATERIALS COMBINATION

Valve Body : Spheroidal graphite cast iron: EN-GJS-400-18 (EN-JS1025)	Bonnet: ASTM A105
	Plugs: ASTM 351 CF8M Seats: ASTM A182 F316
Valve Body : Carbon steel A216 WCC	Bonnet: ASTM A105
	Plugs: ASTM 351 CF8M Seats: ASTM A182 F316
Valve Body : Stainless steel A351 CF8M	Bonnet : ASTM A182 F316
	Plugs: ASTM 351 CF8M Seats: ASTM A182 F316

EQUIVALENZA MATERIALI CORPO

	European Std	ASTM Std	Limiti di Temperatura Temperature Application Limits
Ghisa GGG40.3 Ductil Iron GGG40.3	EN-GJS-400-18	A395	-10+350°C
Acciaio al Carbonio Carbon Steel	1.0619 GP240GH	A216 WCC	-29+427°C
Acciaio Inox Stainless Steel	1.4408 X5CrNiMo	A351 CF8M	-196+600°C

BODY MATERIALS CROSS REFERENCE

MATERIALI DISPONIBILI SU RICHIESTA

Acciai al Carbonio	ASTM A352 LC2 - A352 LC3
Acciai al Carbonio Legati	ASTM A217 WC6
Acciai Inossidabili Austenitici	ASTM : A351 CF8 - A351 CF8M EN 10213-4 : 1.4409 - 1.4308 - 1.4409 - 1.4581
Acciai Inossidabili Ferritici Astenitici (DUPLEX / SUPERDUPLEX)	EN 10213-4 : 1.4517 - 1.4470 - 1.4469

MATERIALS AVAILABLE ON REQUEST

Carbon steel	ASTM A352 LC2 - A352 LC3
Alloy Carbon Steel	ASTM A217 WC6
Austenitic Stainless Steel	ASTM : A351 CF8 - A351 CF8M EN 10213-4 : 1.4409 - 1.4308 - 1.4409 - 1.4581
Ferritic Austenitic Stainless Steel (DUPLEX / SUPERDUPLEX)	A995 CD3MWCuN - A995 A6 A351 CK3MCuN - A351 CE8MC A351 CD3MN - A351 CD4MCuN

GHISA DUTTILE / DUCTILE IRON

EN-GJS-400-18-RT (5.3104) (-10°+350°)

T (°C)	PN16 (bar)
-10 ÷ 120	16
150	15,5
200	14,7
250	13,9
300	12,8
350	11,2

ACCIAI AL CARBONIO / CARBON STEEL

GP240GHN (-29°+450°) - ASTM A105 (-29°+450°C) - EN 10273 1.0345 (-29°+450°C)

T (°C)	PN16 (bar)	PN40 (bar)
RT	16,0	40,0
100	14,8	37,1
150	14,0	35,2
200	13,3	33,3
250	12,1	30,4
300	11,0	27,6
350	10,2	25,7
400	9,5	23,8
450	5,2	13,1

A216 WCB (-29°+450°C) - A216 WCC (-29°+450°C)

T (°C)	PN16 (bar)	PN40 (bar)
RT	16,0	40,0
100	16,0	40,0
150	16,0	40,0
200	16,0	40,0
250	15,6	39,0
300	14,0	35,2
350	12,9	32,3
400	11,8	29,5
450	6,4	16,1

A352 LC2 (-73°+342°C) - A352 LC3 (-101°+342°C)

T (°C)	PN16 (bar)	PN40 (bar)
RT	16,0	40,0
100	16,0	40,0
150	16,0	40,0
200	15,0	37,5
250	13,7	34,4
300	11,9	29,9
342	10,4	26,0
400	//	//
450	//	//

ACCIAI INOSSIDABILI / STAINLESS STEEL

A351 CF8 (-253°+600°C) - EN 10213-4 1.4409 (-253°+600°C) - A182 F304L (-253°+425°C)

T (°C)	PN16 (bar)	PN40 (bar)
RT	16,0	40
100	13,7	34,4
150	12,3	30,8
200	11,2	28,0
250	10,4	26,0
300	9,6	24,1
350	9,2	23,0
400	8,8	22,0
450	8,5	21,4
500	8,3	20,7
550	7,0	17,5
560	6,4	16,1
570	5,9	14,8
580	5,4	13,7
590	4,9	12,3
600	4,4	11,2

A351 CF8M (-253°+600°C) - EN 10213-4 1.4408 (-253°+600°C) - A182 F316H (-29°+600°C)
A182 F316 (-253°+600°C) - EN 10272 1.4529 (-253°+600°C)

T (°C)	PN16 (bar)	PN40 (bar)	T (°C)	PN16 (bar)	PN40 (bar)
RT	16,0	40,0	450	10,7	26,9
100	16,0	40,0	500	10,5	26,4
150	14,5	36,3	550	10,4	26,0
200	13,4	33,7	560	10,3	25,7
250	12,7	31,8	570	10,1	25,4
300	11,8	29,7	580	10,0	25,0
350	11,4	28,5	590	9,9	24,7
400	10,9	27,4	600	8,9	22,4

RIVESTIMENTI PROTETTIVI STANDARD

Corpo Valvola	per temperature $\geq -10 / \leq 150^{\circ}\text{C}$	- Fondo bicomponente acrilico anticorrosivo ad alta resistenza - Finitura con smalto acrilico alifatico bicomponente RAL 7021 opaco
	per temperature $>150 / \leq 250^{\circ}\text{C}$	- Fondo siliconico - Finitura smalto siliconico RAL 9005
	per temperature $>250 / \leq 400^{\circ}\text{C}$	- Fondo siliconico termoresistente - Finitura smalto siliconico RAL 9006
Bonnet	per temperature $\geq -10 / \leq 400^{\circ}\text{C}$	- Zincatura elettrolitica Fe/Zn 8 c1A UNI ISO 4520

STANDARD PROTECTIVE COATING

Valve Body	for temperature $\geq -10 / \leq 150^{\circ}\text{C}$	- Bicomponent anticorrosive acrylic primer at high resistance - Finish with bicomponent aliphatic acrylic enamel RAL 7021 opaque
	for temperature $>150 / \leq 250^{\circ}\text{C}$	- siliconic primer - Finish with siliconic enamel RAL 9005
	for temperature $>250 / \leq 400^{\circ}\text{C}$	- Heat resistant siliconic primer - Finish with siliconic enamel RAL 9006
Bonnet	per temperature $\geq -10 / \leq 400^{\circ}\text{C}$	- Electrolytic zinc coatings Fe/Zn 8 c1A UNI ISO 4520

RIVESTIMENTI PROTETTIVISU RICHIESTA

Corpo valvola e bonnet	- verniciatura per ambienti salini - verniciatura su specifica cliente
------------------------	---

PROTECTIVE COATING ON REQUEST

Valve Body & Bonnet	- Painting for see environment - Customer specification
---------------------	--

BONNET

STANDARD	Standard per temp. $-5 \pm 200^{\circ}\text{C}$
A RICHIESTA	Alettato per temp. $>200^{\circ}\text{C}$
	Allungato per temp. $<-5^{\circ}\text{C}$

BONNET

STANDARD TYPE	Standard for $-5 \pm 200^{\circ}\text{C}$
ON REQUEST	Finned for temp. $>200^{\circ}\text{C}$
	Extended for temp. $<-5^{\circ}\text{C}$



Extended / Prolungato

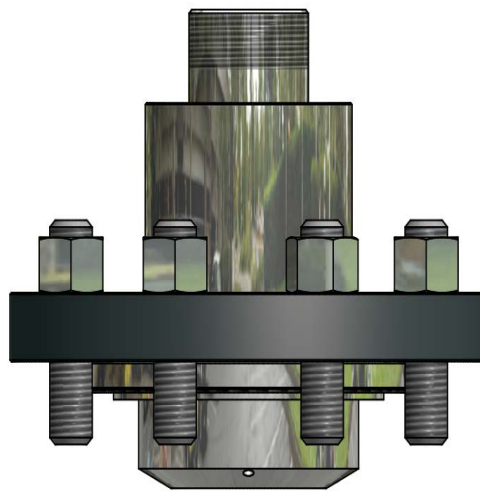



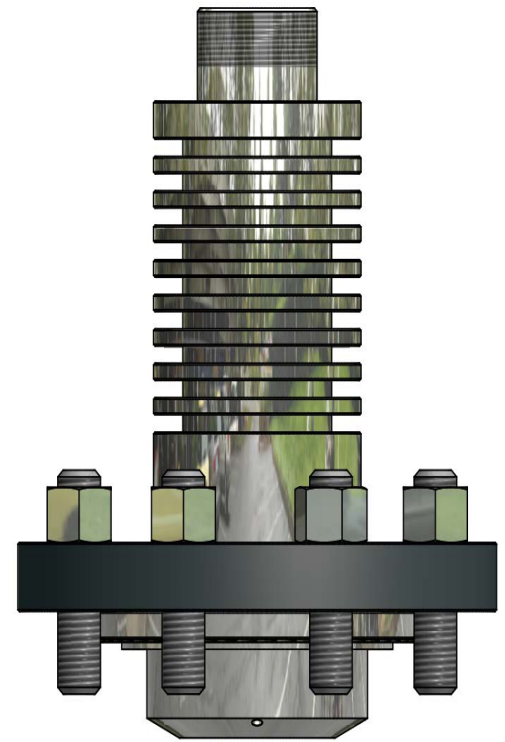











Standard



Finned / Alettato

TENUTA STELO

PACKING

HT200 per temp. $\leq 200^{\circ}\text{C}$ Standard da DN15 a DN100	
GR20 - GRAFITE PURA $\leq 400^{\circ}\text{C}$ Standard da DN125 a DN200	
HTS300 per temp. $\leq 400^{\circ}\text{C}$ A richiesta da DN15 a DN100	
GreenPack 1 per temp. $\leq 450^{\circ}\text{C}$ Basse emissioni / Autoestinguenta A richiesta da DN15 a DN100	Ta-Luft  
GreenPack 2 per temp. $\leq 450^{\circ}\text{C}$ Basse emissioni / Autoestinguenta A richiesta da DN125 a DN200	Ta-Luft 
ZEB20 - Soffietto per fluidi pericolosi - Zero Emissioni A richiesta da DN15 a DN200	 
HT200 for temp. $\leq 200^{\circ}\text{C}$ Standard from DN15 to DN100	
GR20 - PURE GRAPHITE $\leq 400^{\circ}\text{C}$ Standard from DN125 to DN200	
HTS300 for temp. $\leq 400^{\circ}\text{C}$ On Request from DN15 to DN100	
GreenPack 1 for temp. $\leq 450^{\circ}\text{C}$ Low Emissions / Firesafe On Request from DN15 to DN100	Ta-Luft  
GreenPack 2 for temp. $\leq 450^{\circ}\text{C}$ Low Emissions / Firesafe On Request from DN125 to DN200	Ta-Luft 
ZEB20 - Bellows sealed for dangerous fluids - Zero Emissions On Request from DN15 to DN200	 

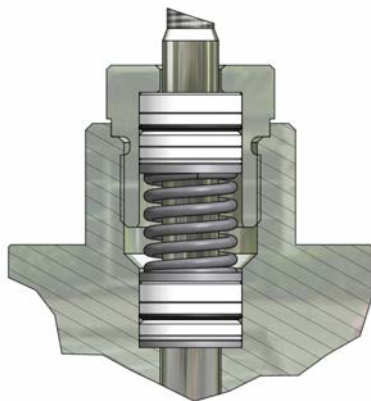

HT200



ZEB20

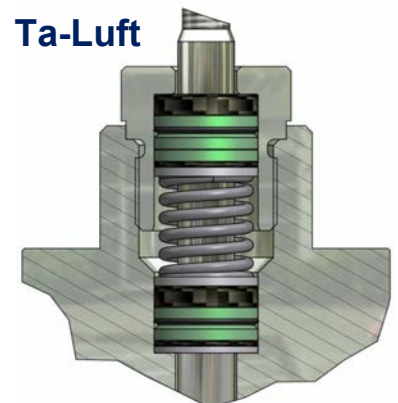

GreenPack 1

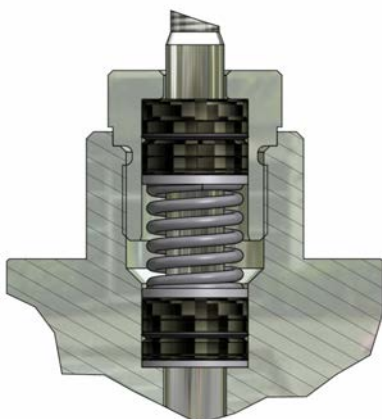

HTS300

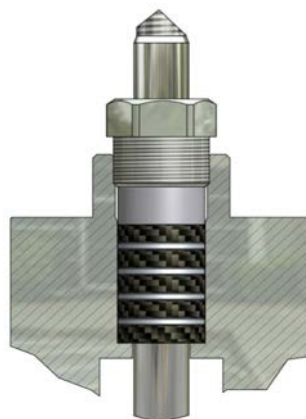

GR20

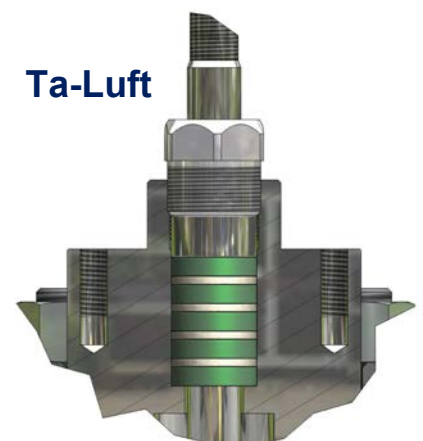

GreenPack 2

CARATTERISTICHE OTTURATORE

PLUG CHARACTERISTICS

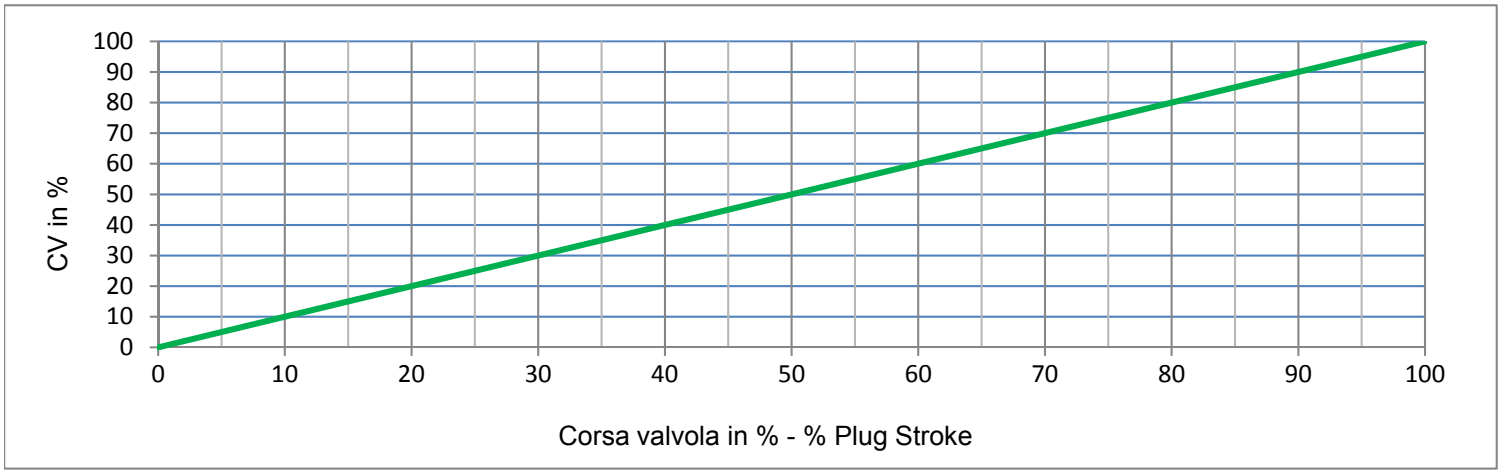

TRIMS

TENUTA	Tenuta metallica - Classe IV°
PROFILO OTTURATORE	Lineare (PL)
PASSAGGIO	Integrale
A RICHIESTA	Passaggio ridotto
	Indurito da Nitrurazione Salina

TRIMS

SEAL	Metal seat tightness - Class IV°
PLUG TYPES	Linear (PL)
PORT	Full Port
ON REQUEST	Reduced port
	Hardened by Saline Nitriding

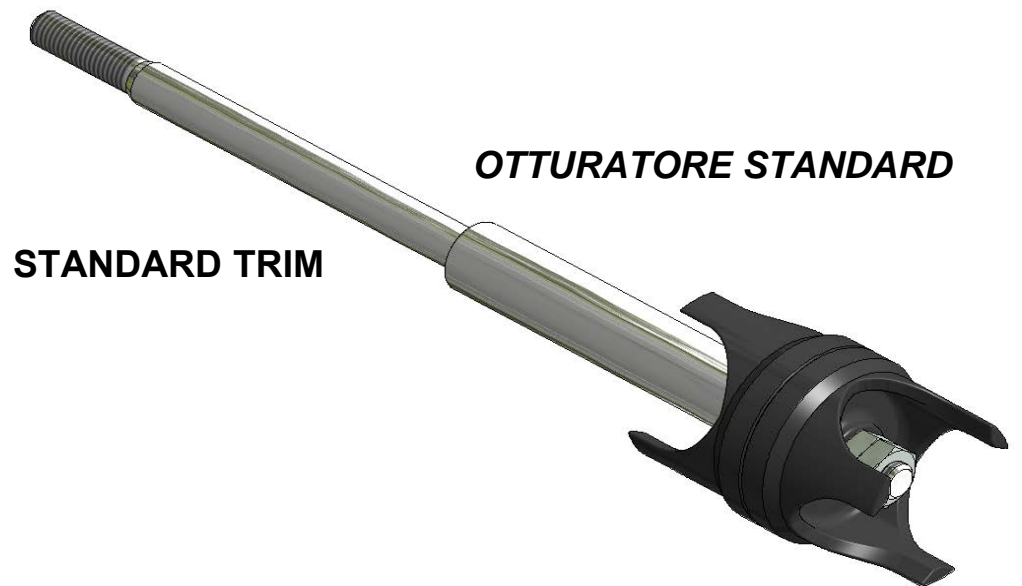

	Corsa / Stroke		
CV (flow rate coefficients)	0,05 ÷ 47	73 ÷ 160	270 ÷ 650
mm	20	30	50

COEFFICIENTI DI PORTATA

(CV= portata in GPM con 1 psi di pressione differenziale)
(Kv= portata in m³/h con 1 bar di pressione differenziale)

FLOW RATE COEFFICIENTS

(CV= flowrate in USGPM with 1 psi of differential Pressure)
(Kv= flowrate in m³/h with 1 bar of differential Pressure)

CV	DIAMETRO NOMINALE - SIZES											
	15	20	25	32	40	50	65	80	100	125	150	200
4.5	std	■	■	■	■							
6		std	■	■	■	■						
11			std	■	■	■	■					
18				std	■	■	■	■				
27					std	■	■	■	■			
47						std	■	■	■	■		
73							std	■	■	■	■	
105								std	■	■	■	■
160									std	■	■	■
270										std	■	■
370											std	■
650												std

non disponibile / not available

std

standard

■

su richiesta / on request

ATTUATORE PNEUMATICO DI REGOLAZIONE

PRESSIONI DIFFERENZIALI MASSIME

AMMISSIBILI IN BAR (Fluido Apre)

PER COSTRUZIONI CON OTTURATORI NON BILANCIATI

CONTROL PNEUMATIC ACTUATOR

MAXIMUM ADMISSIBLE PRESSURE

DROPS IN BAR (Fluid Open)

FOR UNBALANCED CONSTRUCTION

ATTUATORE ACTUATOR	SEGNALE SIGNAL (psi)	CV 4.5	CV 6	CV 11	CV 18	CV 27	CV 47	CV 73	CV 105	CV 160	CV 270	CV 370	CV 650
		cl. IV	cl. IV	cl. IV	cl. IV	cl. IV	cl. IV	cl. IV	cl. IV	cl. IV	cl. IV	cl. IV	cl. IV
AP23	3÷15	15	14	9	5	3	2	-	-	-	-	-	-
	6÷18	18	16	11	7	4	3	-	-	-	-	-	-
	6÷30	50	22	16	10	6	4	-	-	-	-	-	-
	15÷60	70	45	35	27	15	8	-	-	-	-	-	-
AP28	3÷15	31	27	17	8	6	4	-	-	-	-	-	-
	6÷18	40	38	21	13	10	5	-	-	-	-	-	-
	6÷30	55	50	26	23	12	7	-	-	-	-	-	-
	15÷60	99	80	48	40	25	17	-	-	-	-	-	-
AP34 / AP35	3÷15	60	60	50	20	12	10	4	2	1	-	-	-
	6÷18	80	80	60	30	15	12	6	4	2	-	-	-
	6÷30	99	99	80	40	20	14	7	5	2	-	-	-
	15÷60	-	-	-	62	36	25	11	8	6	-	-	-
AP43 / AP44	3÷15	-	-	-	-	35	24	7	6	4	-	-	-
	6÷18	-	-	-	-	40	26	9	8	5	-	-	-
	6÷30	-	-	-	-	40	26	12	10	6	-	-	-
	15÷60	-	-	-	-	65	40	28	22	15	-	-	-
AP45	15÷60	-	-	-	-	65	40	28	22	15	-	-	-
AP46	15÷60	-	-	-	-	-	-	-	-	-	7	5	3

I valori espressi in tabella si riferiscono alla forza del servomotore, il rating del corpo ne limita l'applicazione.

The pressure drop values must be used within the body rating limit.

TIPO ATTUATORE	multimolla a membrana	
SEGNALI DI COMANDO	3÷15 psi 6÷18 psi 6÷30 psi	15÷60 psi
PRESSIONE MAX APPLICABILE	50 psi (3,5 bar)	87 psi (6 bar)
TEMPERATURA AMBIENTE	-20÷70°C	
MATERIALE CUSTODIA	Acciaio al Carbonio Fe410.1	
CASTELLO	Tipo Integrale in Acciaio al Carbonio ASTM A216 WCB	
MATERIALE MEMBRANA	NBR70 telata	
CONNESSIONI PNEUMATICHE	1/4"NPT-F	

TYPE	diaphragm type - multispring	
CONTROL SIGNAL	3÷15 psi 6÷18 psi 6÷30 psi	15÷60 psi
MAX AIR SUPPLY PRESSURE	50 psi (3,5 bar)	87 psi (6 bar)
AMBIENT TEMPERATURE	-20÷70°C	
ACTUATOR CASING MATERIAL	Carbon Steel Fe410.1	
YOKE MATERIAL	Integral Type in Carbon steel ASTM A216 WCB	
DIAPHRAGM MATERIAL	NBR70	
PNEUMATIC CONNECTIONS	1/4"NPT-F	

RIVESTIMENTI PROTETTIVI

Standard	Verniciatura a polvere poliestere RAL 7032 (*)
----------	--

* altre verniciature sono disponibili su richiesta

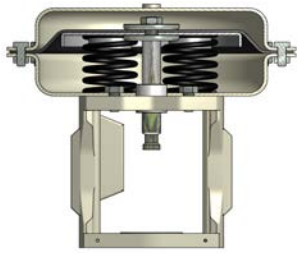

Fig.1

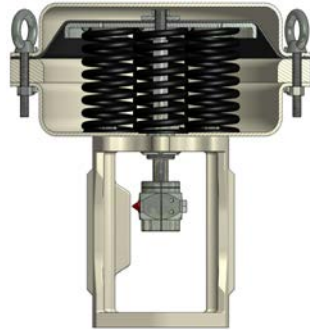

Fig.3

AZIONE DIRETTA	(Fig.1/ Fig.3)
AZIONE INVERSA	(Fig.2 / Fig.4)

PROTECTIVE COATING

Standard	Finish powder coat polyesrer RAL 7032 (*)
----------	---

* other painting cycle are available on request

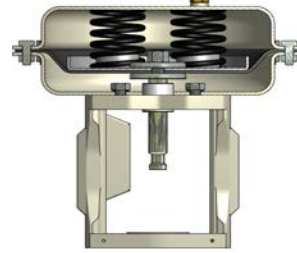

Fig.2

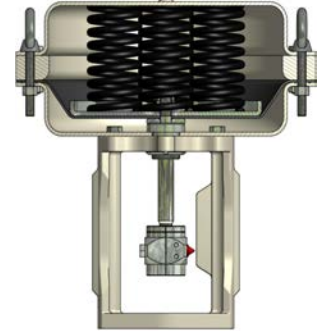

Fig.4

DIRECT ACTION	(Fig.1 / Fig.3)
REVERSE ACTION	(Fig.2 / Fig.4)

ACCESSORI DISPONIBILI

Contatti di allarme
Posizionatore elettropneumatico
Posizionatore pneumatico
Posizionatore SMART
Convertitore I/P
Trasmettitore di posizione
Filtro riduttore
Volantino di manovra
Elettrovalvole
Dispositivo pneumatico di blocco (Lock UP)

ACCESSORIES

Alarm contacts
Elettropneumatic positioner
Pneumatic positioner
SMART positioner
I/P Converter
4-20 mA Position feedback
Air filter regulator
Top mounted handwheel
Solenoid valves
Lock-Up pneumatic device

VARIANTI DISPONIBILI

Castello INOX
Custodia INOX
Viteria INOX
Verniciatura per ambienti Marini

OPTIONS

St. Steel yoke
St. Steel casing
St. Steel bolts & nuts
Off-Shore painting

DIMENSIONI (mm)

DIMENSIONS (mm)

DN	A	B	N. Fori Nr. Holes	C (bonnet)			
				Otturatore Standard / Standard Trim			
				Standard	Alettato <i>Finned</i>	Prolungato <i>Extended</i>	Soffietto <i>Bellows</i>
DN 15	130	70	4	132	169	169	232
DN 20	150	80	4	133	170	170	233
DN 25	160	85	4	138	182	182	237
DN 32	180	100	4	133	177	177	232
DN 40	200	105	4	138	195	195	236
DN 50	230	120	4	147	204	204	245
DN 65	290	130	4 or 8 (*)	177	267	267	304
DN 80	310	140	8	191	264	264	310
DN 100	350	150	8	182	308	308	305
DN 125	400	235	8	286	399	399	399
DN 150	480	250	8	297	410	410	410
DN 200	600	275	12	298	410	410	410

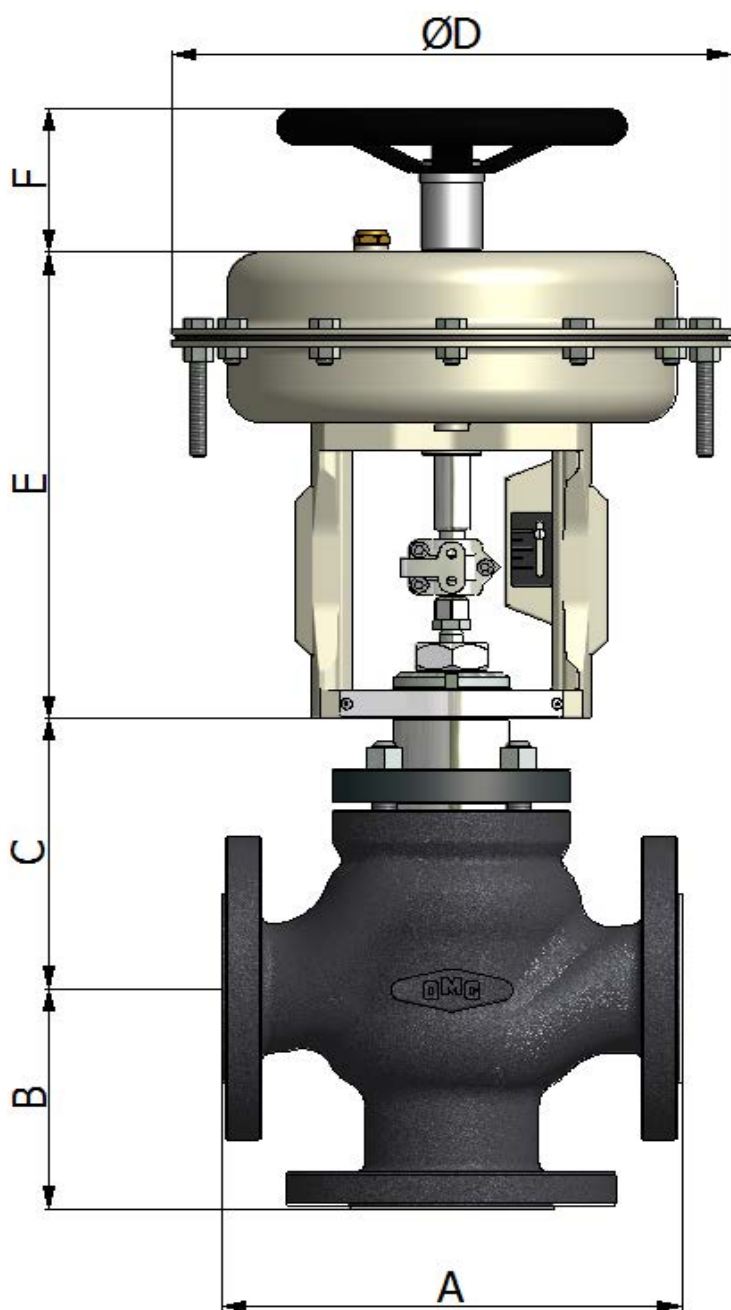

***ATTENZIONE!**

In accordo alla norma EN1092-1 le flange DN65 PN16 in acciaio devono essere fornite con 8 fori. Possono essere fornite con 4 fori solo su specifica richiesta del committente.

In accordo alla norma EN1092-2 le flange DN65 PN16 in ghisa devono essere fornite con 4 fori. Possono essere fornite con 8 fori solo su specifica richiesta del committente.

In accordo alle norme EN1092-1 e 2 le valvole DN65 PN40 sono fornite con 8 fori

***ATTENTION!**

According to standard EN1092-1 DN65 valves in carbon steel and stainless steel flanged PN16 must be provided with 8 holes. They can be supplied with 4 holes only at the specific request of the customer.

According to standard EN1092-2 DN65 valves in ductile iron flanged PN16 must be provided with 4 holes. They can be supplied with 8 holes only at the specific request of the customer.

According to standards EN1092-1 and 2, the valves DN65 PN16 must be provided with 8 holes

SERVOMOTORE (mm) - ACTUATOR (mm)

TIPO TYPE	Ø D	E	F
AP23	230	245	110
AP28	275	253	110
AP34 / AP35	335	276	150
AP43 / AP44	430	303	300
AP45	430	393	
AP46	430	425	

ATTUATORE PNEUMATICO A PISTONE

PISTON PNEUMATIC ACTUATOR

PRESSIONI DIFFERENZIALI MASSIME AMMISSIBILI IN
BAR (Fluido Apre)

MAXIMUM PERMISSIBLE PRESSURE DROPS IN BAR
(Fluid Open)

TYPE	Ø	SEGNALE SIGNAL	CV								
			0.05 ÷ 4.5	6	11	18	27	47	73	105	160
OP10	DN15 ÷ DN50	6÷10 bar	175psi (12Bar)	175psi (12Bar)	175psi (12Bar)	175psi (12Bar)	175psi (12Bar)	145psi (10Bar)			
OP16	DN65 ÷ DN100	6÷10 bar							175psi (12Bar)	116psi (8Bar)	45psi (3Bar)

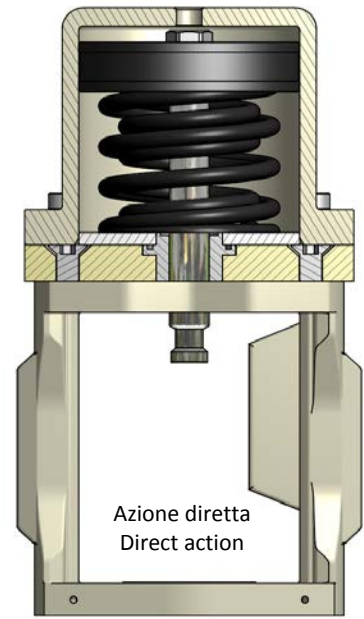
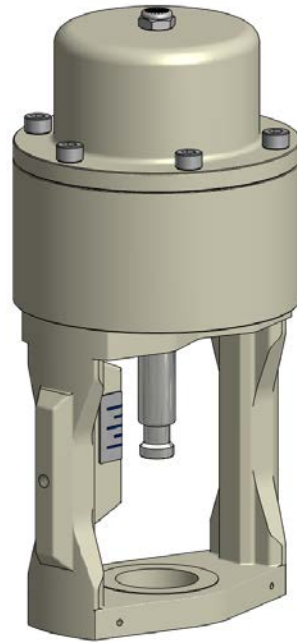
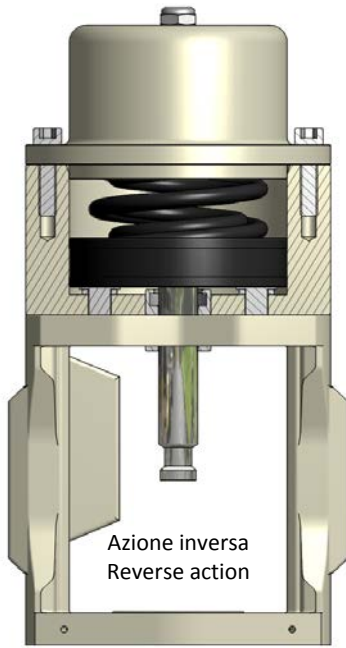

TIPO ATTUATORE	a pistone con multimolle interne	TYPE	piston type - multispring
SEGNALI DI COMANDO	da 90 psi (6 Bar) a 145psi(10 bar)	CONTROL SIGNAL	from 90psi(6 Bar) to 145psi(10bar)
MASSIMA PRESSIONE ARIA APPLICABILE	145 psi (10 bar)	MAX AIR SUPPLY PRESSURE	145 psi (10 bar)
TEMPERATURA AMBIENTE	-20÷70°C	AMBIENT TEMPERATURE	-20÷70°C
MATERIALE CASSA	Alluminio verniciato RAL7021	ACTUATOR CASTING MATERIAL	Alluminium anti corrosive paint RAL7021
CASTELLO A COLONNE	Tipo Integrale in Acciaio al carbonio	YOKE MATERIAL	Integral Type in Carbon steel
CONNESSIONI PNEUMATICHE	1/4"NPT-F	PNEUMATIC CONNECTIONS	1/4"NPT-F

ACCESSORI E VARIANTI DISPONIBILI

OPTIONS AND ACCESSORIES

Contatti di allarme	Alarm contacts
Elettrovalvole	Solenoid valves
Verniciatura per ambienti Marini	Off-Shore painting

DIMENSIONI (mm)
DIMENSIONS (mm)

DN	A	B	N. Fori Nr. Holes	C (bonnet)			
				Otturatore Standard / Standard Trim			
				Standard	Alettato <i>Finned</i>	Prolungato <i>Extended</i>	Soffietto <i>Bellows</i>
DN 15	130	70	4	132	169	169	232
DN 20	150	80	4	133	170	170	233
DN 25	160	85	4	138	182	182	237
DN 32	180	100	4	133	177	177	232
DN 40	200	105	4	138	195	195	236
DN 50	230	120	4	147	204	204	245
DN 65	290	130	4 or 8 (*)	177	267	267	304
DN 80	310	140	8	191	264	264	310
DN 100	350	150	8	182	308	308	305

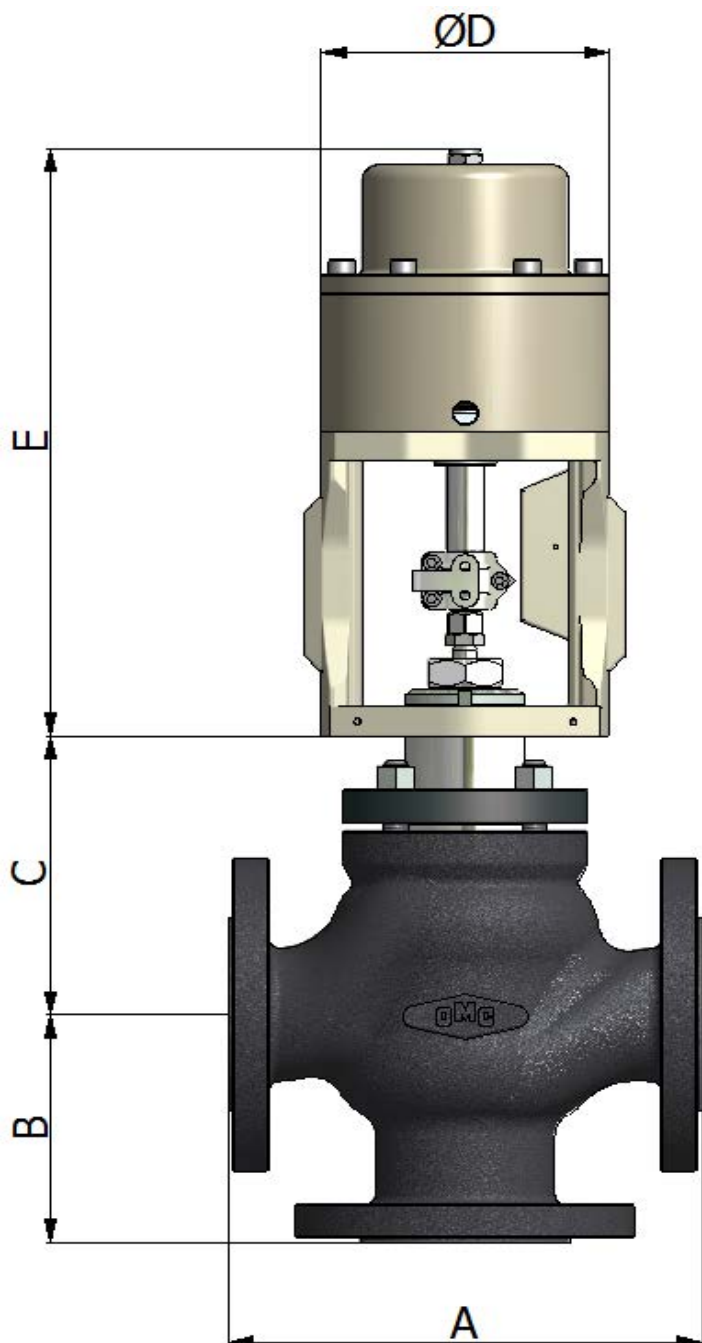
***ATTENZIONE!**

In accordo alla norma EN1092-1 le flange DN65 PN16 in acciaio devono essere fornite con 8 fori. Possono essere fornite con 4 fori solo su specifica richiesta del committente.

In accordo alla norma EN1092-2 le flange DN65 PN16 in ghisa devono essere fornite con 4 fori. Possono essere fornite con 8 fori solo su specifica richiesta del committente.

In accordo alle norme EN1092-1 e 2 le valvole DN65 PN40 sono fornite con 8 fori

***ATTENTION!**

According to standard EN1092-1 DN65 valves in carbon steel and stainless steel flanged PN16 must be provided with 8 holes. They can be supplied with 4 holes only at the specific request of the customer.

According to standard EN1092-2 DN65 valves in ductile iron flanged PN16 must be provided with 4 holes. They can be supplied with 8 holes only at the specific request of the customer.

According to standards EN1092-1 and 2, the valves DN65 PN16 must be provided with 8 holes

SERVOMOTORE - ACTUATOR

TIPO TYPE	Ø D (mm)	E (mm)		
		DN15-DN40	DN50-DN65	DN80-DN100
OP10	140	267	292	/
OP16	192	/	/	335

ATTUATORE ELETTRICO

TIPO ATTUATORE	Elettrico
SEGNALI DI COMANDO	0÷10 VDC - 2÷10 VDC 0÷20 mA - 4÷20 mA
SEGNALE DI USCITA	0÷10 VDC Std
GRADO DI PROTEZIONE STD	IP54

ELECTRIC ACTUATOR

TYPE	Electric
CONTROL SIGNAL	0÷10 VDC - 2÷10 VDC 0÷20 mA - 4÷20 mA
OUTPUT SIGNAL	0÷10 VDC Std
STD ENCLOSURE PROTECTION	IP54

TIPO	FORZA	CORSA MAX pollici (mm)	TEMPO DI AZIONAMENTO
MC 103	1.0 kN	0,78 (20 mm)	12 • 9 • 4 • 9 s/mm
MC 163	1.6 kN	1,18 (30 mm)	6 • 4 s/mm
MC 253	2,5 kN	2,36 (60 mm)	5 • 2,5 s/mm
MC 403	4 kN	2,36 (60 mm)	0,6 • 0,4 s/mm
MC 503	5 kN	2,36 (60 mm)	5 • 2,5 s/mm
MC 1003	10 kN	3,15 (80 mm)	1 s/mm
MC 1503	15 kN	3,15 (80 mm)	2 s/mm

TYPE	THRUST	MAX STROKE inches (mm)	ACTUATING TIME
MC 103	1.0 kN	0,78 (20 mm)	12 • 9 • 4 • 9 s/mm
MC 163	1.6 kN	1,18 (30 mm)	6 • 0,4 s/mm
MC 253	2,5 kN	2,36 (60 mm)	5 • 2,5 s/mm
MC 403	4 kN	2,36 (60 mm)	0,6 • 0,4 s/mm
MC 503	5 kN	2,36 (60 mm)	5 • 2,5 s/mm
MC 1003	10 kN	3,15 (80 mm)	1 s/mm
MC 1503	15 kN	3,15 (80 mm)	2 s/mm

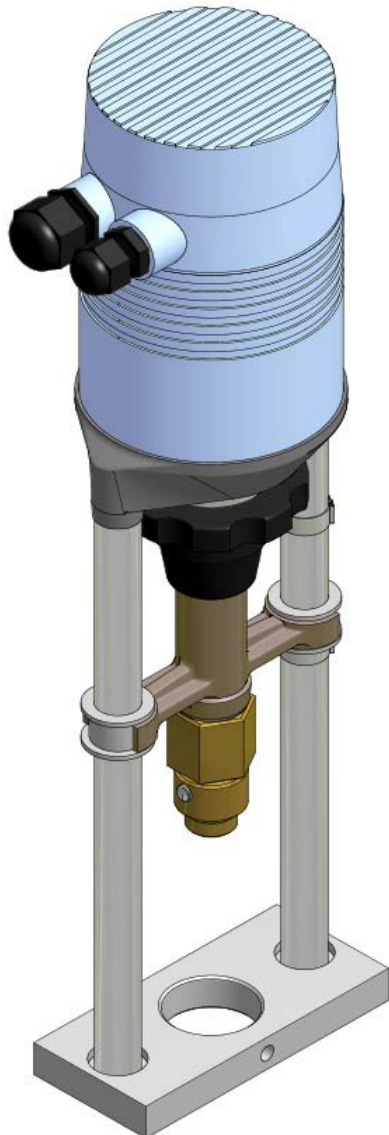

230Vac

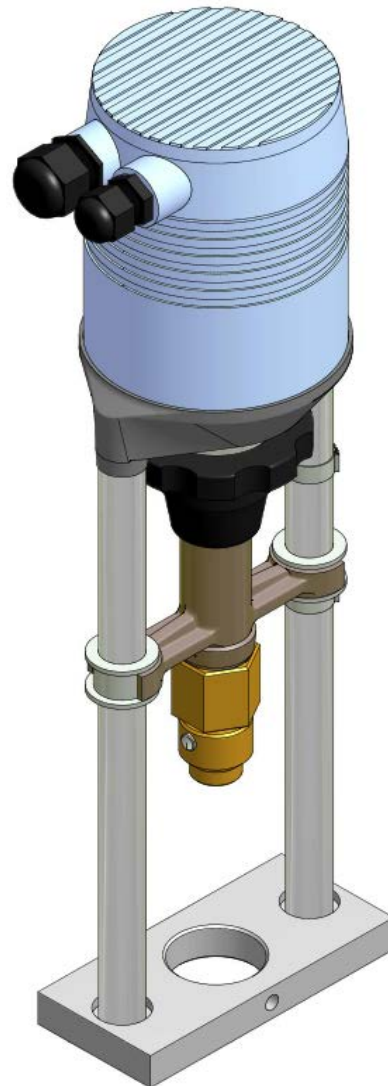

24Vac

DIMENSIONI (mm)
DIMENSIONS (mm)

DN	A	B	N. Fori Nr. Holes	C (bonnet)			
				Otturatore Standard / Standard Trim			
				Standard	Alettato Finned	Prolungato Extended	Soffietto Bellows
DN 15	130	70	4	132	169	169	232
DN 20	150	80	4	133	170	170	233
DN 25	160	85	4	138	182	182	237
DN 32	180	100	4	133	177	177	232
DN 40	200	105	4	138	195	195	236
DN 50	230	120	4	147	204	204	245
DN 65	290	130	4 or 8 (*)	177	267	267	304
DN 80	310	140	8	191	264	264	310
DN 100	350	150	8	182	308	308	305
DN 125	400	235	8	286	399	399	399
DN 150	480	250	8	297	410	410	410
DN 200	600	275	12	298	410	410	410

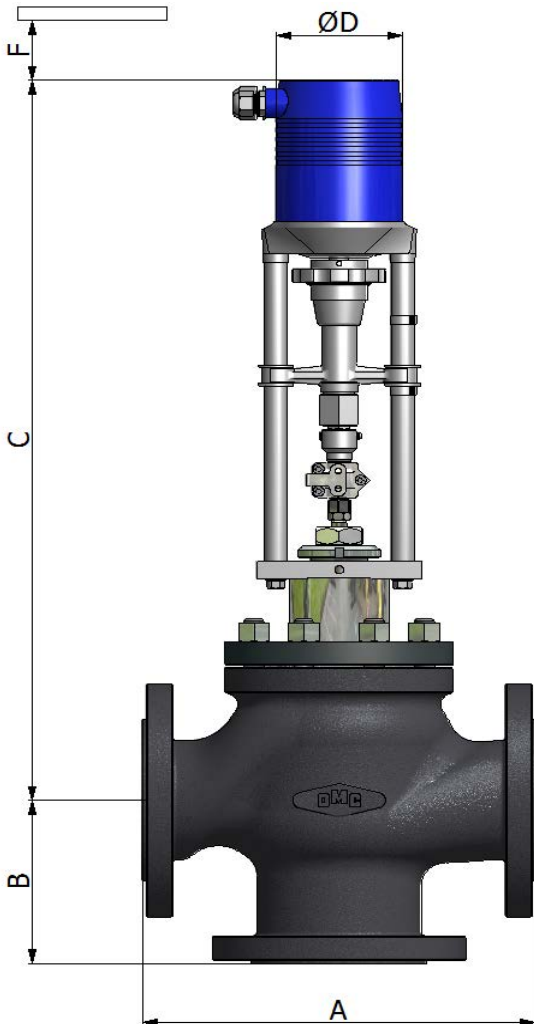
***ATTENZIONE!**

In accordo alla norma EN1092-1 le flange DN65 PN16 in acciaio devono essere fornite con 8 fori. Possono essere fornite con 4 fori solo su specifica richiesta del committente.

In accordo alla norma EN1092-2 le flange DN65 PN16 in ghisa devono essere fornite con 4 fori. Possono essere fornite con 8 fori solo su specifica richiesta del committente.

In accordo alle norme EN1092-1 e 2 le valvole DN65 PN40 sono fornite con 8 fori

***ATTENTION!**

According to standard EN1092-1 DN65 valves in carbon steel and stainless steel flanged PN16 must be provided with 8 holes. They can be supplied with 4 holes only at the specific request of the customer.

According to standard EN1092-2 DN65 valves in ductile iron flanged PN16 must be provided with 4 holes. They can be supplied with 8 holes only at the specific request of the customer.

According to standards EN1092-1 and 2, the valves DN65 PN16 must be provided with 8 holes

TIPO	Ø D (mm)	E (mm)	F (mm)
MC 103 (24Vac)	100	376	140
MC 103 (230Vac)	100	401	140
MC 163 (24Vac)	100	428	140
MC 163 (230Vac)	100	453	140
MC 253 / MC 503	135	670	200
MC 403	135	670	200
MC 1003 / MC 1503	135	770	200

ACCESSORI E VARIANTI DISPONIBILI
OPTIONS AND ACCESSORIES

Grado di protezione IP65	Enclosure protection IP65
Ritrasmissione 4-20 mA	4-20 mA Feedback
Finecorsa	Limit switches
Motori elettrici con molla di ritorno	Spring return electric actuator
Motori elettrici ATEX & explosion proof (Exd)	ATEX & explosion proof (Exd) electric actuator

PESI ATTUATORI PNEUMATICI
PNEUMATIC ACTUATOR WEIGHT

TIPO TYPE	SEGNALE SIGNAL (psi)	ATTUATORE ACTUATOR Kg	VOLANTINO MANUALE HAND WHEEL Kg	TIPO TYPE	SEGNALE SIGNAL (psi)	ATTUATORE ACTUATOR Kg	VOLANTINO MANUALE HAND WHEEL Kg	TIPO TYPE	SEGNALE SIGNAL (psi)	ATTUATORE ACTUATOR Kg	VOLANTINO MANUALE HAND WHEEL Kg
AP23	3÷15	7,3	1	AP34 / AP35	3÷15	14,7	2,1	AP45	15÷60	37,8	7,1
	6÷18	7,4			6÷18	14,9					
	6÷30	7,3			6÷30	15					
	15÷60	7,8			15÷60	17,4					
AP28	3÷15	9,7	1	AP43 / AP44	3÷15	26	3	OP10	ON-OFF	7,5	//
	6÷18	9,8			6÷18	26,5					
	6÷30	9,6			6÷30	26,8					
	15÷60	11,5			15÷60	32,2	7,1	OP16	ON-OFF	12,5	//

PESI ATTUATORI ELETTRICI
ELECTRIC ACTUATOR WEIGHT

TIPO TYPE	24Vac Kg	230Vac Kg	TIPO TYPE	24Vac Kg	230Vac Kg	TIPO TYPE	24Vac Kg	230Vac Kg
MC 103	2,5	2,5	MC 403	9,5	9,5	MC 1503	11,5	11,5
MC 163	4	4	MC 503	7,4	8,6			
MC 253	7,4	8,6	MC 1003	11,5	11,5			

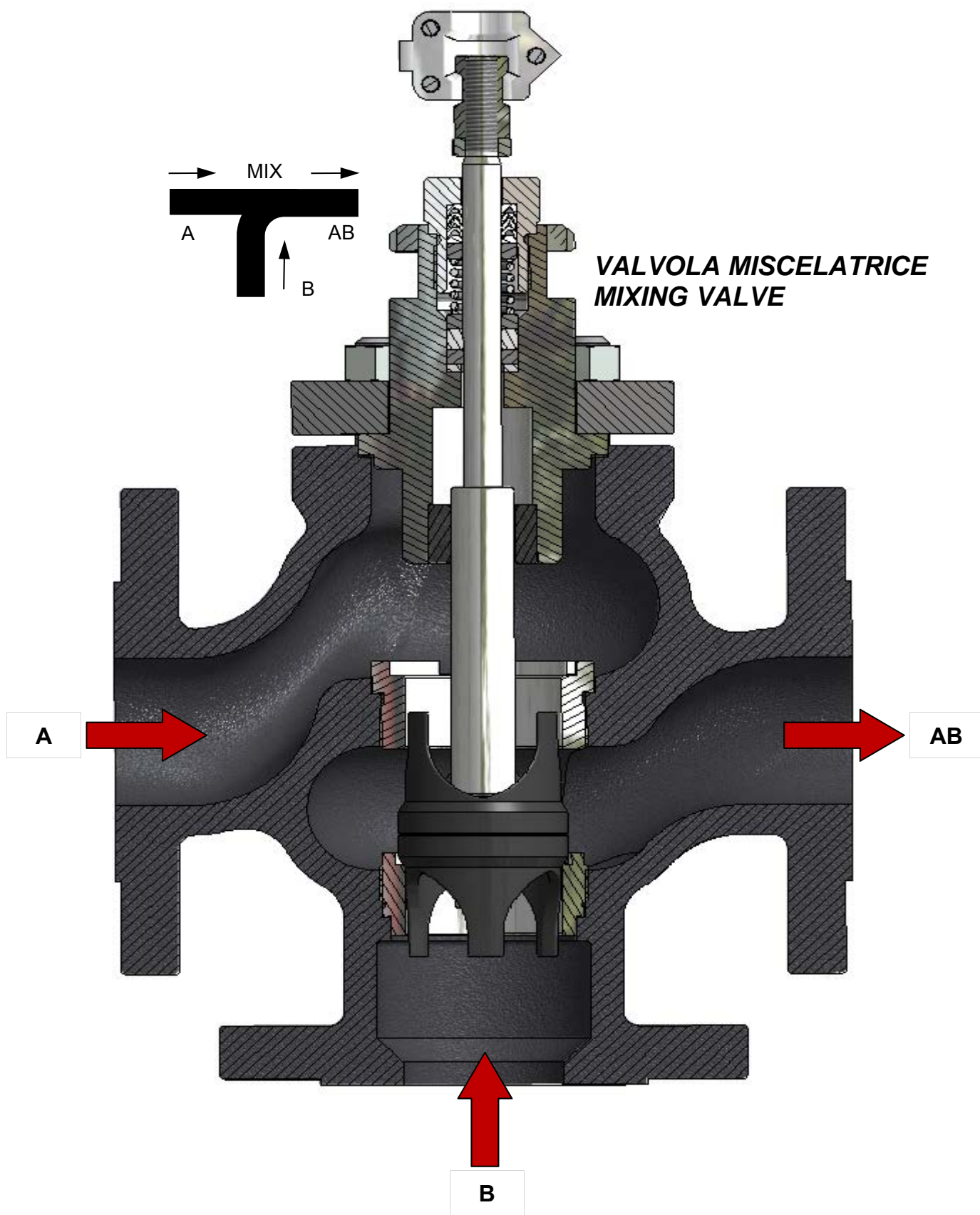

Il contenuto di questa pubblicazione è solo a scopo informativo. OMC si riserva di modificare o migliorare i disegni o le specifiche tecniche senza alcun preavviso
The contents of this publication are presented for information purpose only. We reserve to modify or improve the designs or specifications of such products at any time without notice.



OMC s.r.l.
Via Galileo Galilei, 18 - 20060 - Cassina de Pecchi (MI) - ITALY
Tel.: (+39) 02.95.28.468 - Fax: (+39) 02.95.21.495 - info@omcsrl.com